



## SPT24N65F1A

### 650V 24A Trench FS IGBT

$V_{CE}$	<b>650</b>	<b>V</b>
$I_C$	<b>24</b>	<b>A</b>
$V_{CE(SAT)} I_C=24A$	<b>1.8</b>	<b>V</b>

#### Features

- Max Junction Temperature 150°C
- High breakdown voltage up to 650V for improved reliability
- Short Circuit Rated
- Very Low Saturation Voltage:  
 $V_{CE(SAT)} = 1.8V$  (Typ.) @  $I_C = 24A$
- Enhanced avalanche capability

#### Applications

- Uninterruptible Power Supplies
- Inverter
- Welding
- PFC applications

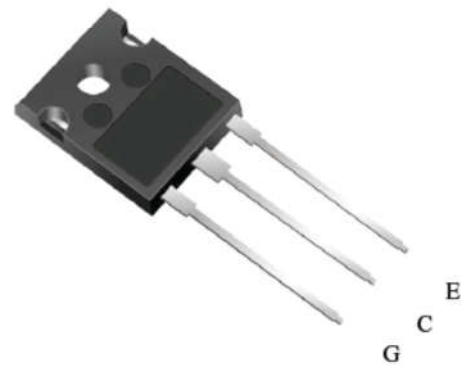
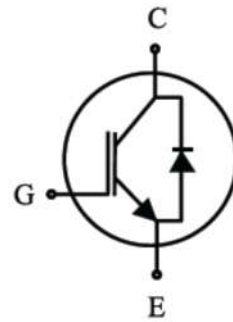

Product	Package	Packaging
SPT24N65F1A	TO247	Tube



**Maximum Ratings** ( $T_j = 25^\circ\text{C}$  unless otherwise specified)

Parameter	Symbol	Value	Unit
Collector-Emitter Breakdown Voltage	$V_{CE}$	650	V
DC collector current, limited by $T_{jmax}$ $T_C = 25^\circ\text{C}$ $T_C = 100^\circ\text{C}$	$I_C$	48 24	A
Diode Forward current, limited by $T_{jmax}$ $T_C = 25^\circ\text{C}$ $T_C = 100^\circ\text{C}$	$I_F$	48 24	A
Turn off safe operating area $V_{CE} \leq 650\text{V}$ , $T_j \leq 150^\circ\text{C}$		80	A
Short Circuit Withstand Time, $V_{GE} = 15\text{V}$ , $V_{CE} \leq 400\text{V}$	$T_{sc}$	5	$\mu\text{s}$
Operating junction temperature $T_j$		-40...+150	$^\circ\text{C}$
Storage temperature	$T_s$	-55...+150	$^\circ\text{C}$
Soldering temperature, wave soldering 1.6mm (0.063in.) from case for 10s		260	$^\circ\text{C}$

**Thermal Resistance**

Parameter	Symbol	Max. Value	Unit
IGBT thermal resistance, junction - case	$R_{\theta(j-c)}$	0.85	K/W
Diode thermal resistance, junction - case	$R_{\theta(j-c)}$	1.3	K/W
Thermal resistance, junction - ambient	$R_{\theta(j-a)}$	40	K/W

**Electrical Characteristics of the IGBT** ( $T_j = 25^\circ\text{C}$  unless otherwise noted)

Symbol	Parameter	Test Conditions	Min.	Typ.	Max.	Units
<b>Static Characteristics</b> (Tested on wafers)						
$BV_{CES}$	Collector to Emitter Breakdown Voltage	$V_{GE} = 0V, I_C = 1mA$	650	-	-	V
$V_{CE(SAT)}$	Collector to Emitter Saturation Voltage	$I_C = 24A, V_{GE} = 15V$	-	1.8	2.1	V
$V_{GE(th)}$	G-E Threshold Voltage	$V_{GE} = V_{CE}, I_C = 250\mu A$	4.1	5.0	5.7	V
$I_{CES}$	Collector Cut-Off Current	$V_{CE} = 650V, V_{GE} = 0V$	-	-	40	$\mu A$
$I_{GES}$	G-E Leakage Current	$V_{GE} = 20V, V_{CE} = 0V$	-	-	$\pm 100$	nA

**Switching Characteristic, Inductive Load** ( $T_j = 25^\circ\text{C}$  unless otherwise specified)

Parameter	Symbol	Conditions	Min	Typ	Max	Unit
<b>Dynamic</b> $T_j = 25^\circ\text{C}$						
Turn-on Delay Time	$t_{d(on)}$	$T_j = 25^\circ\text{C}$ $V_{CC} = 400V, I_C = 24A,$ $V_{GE} = 0/15V,$ $R_g = 12\Omega$	-	30	-	ns
Rise Time	$t_r$		-	20	-	ns
Turn-off Delay Time	$t_{d(off)}$		-	100	-	ns
Fall Time	$t_f$		-	80	-	ns
Turn-on Energy	$E_{on}$		-	1.1	-	mJ
Turn-off Energy	$E_{off}$		-	0.15	-	mJ

**Electrical Characteristics of the DIODE** ( $T_j = 25^\circ\text{C}$  unless otherwise specified)

Parameter	Symbol	Conditions	Min	Typ	Max	Unit
<b>Dynamic</b>						
Diode Forward Voltage	$V_{FM}$	$I_F = 30A$	-	1.6	-	V



**PG-TO247-3**

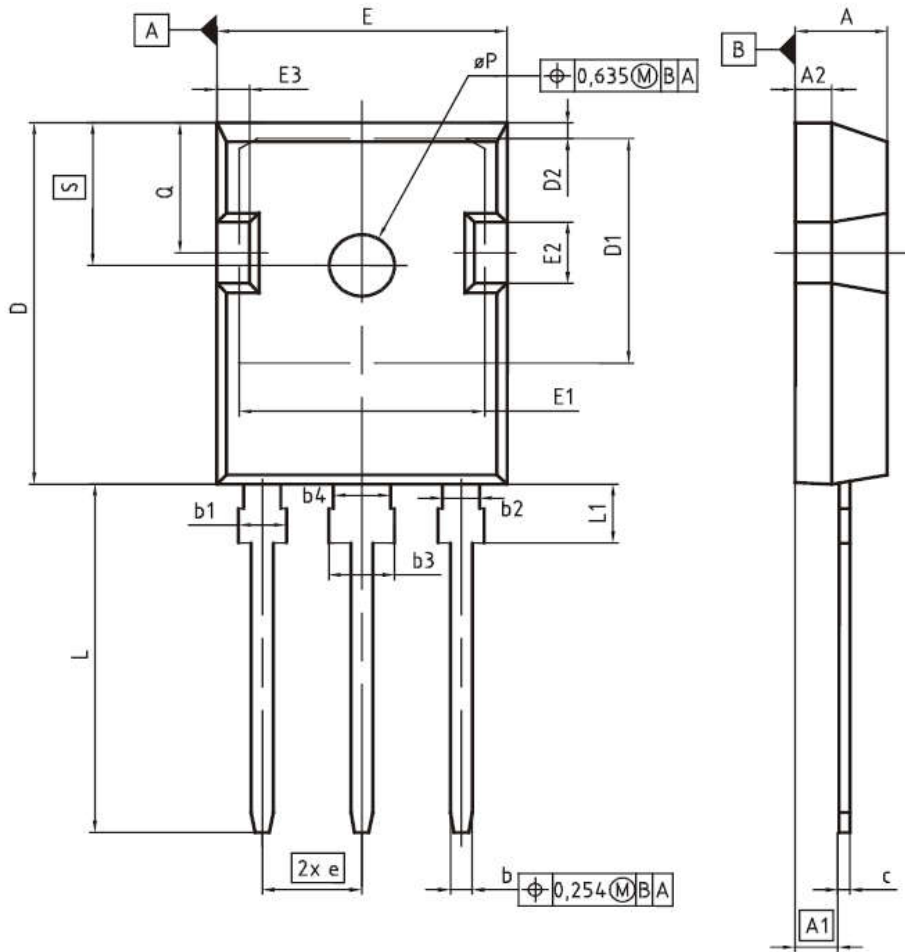

DIM	MILLIMETERS		INCHES	
	MIN	MAX	MIN	MAX
A	4.83	5.21	0.190	0.205
A1	2.27	2.54	0.089	0.100
A2	1.85	2.16	0.073	0.085
b	1.07	1.33	0.042	0.052
b1	1.90	2.41	0.075	0.095
b2	1.90	2.16	0.075	0.085
b3	2.87	3.38	0.113	0.133
b4	2.87	3.13	0.113	0.123
c	0.55	0.68	0.022	0.027
D	20.80	21.10	0.819	0.831
D1	16.25	17.65	0.640	0.695
D2	0.95	1.35	0.037	0.053
E	15.70	16.13	0.618	0.635
E1	13.10	14.15	0.516	0.557
E2	3.68	5.10	0.145	0.201
E3	1.00	2.60	0.039	0.102
e	5.44 (BSC)		0.214 (BSC)	
N	3		3	
L	19.80	20.32	0.780	0.800
L1	4.10	4.47	0.161	0.176
øP	3.50	3.70	0.138	0.146
Q	5.49	6.00	0.216	0.236
S	6.04	6.30	0.238	0.248