

## SPTECH Product Specification

# SPTECH Silicon PNP Power Transistor

# NJW1302G

### DESCRIPTION

- With TO-3PN packaging
- Reliable performance at higher powers
- Accurate reproduction of Input signal
- Greater dynamic range
- Minimum Lot-to-Lot variations for robust device performance and reliable operation

### APPLICATIONS

- Switching regulators
- High frequency inverters
- General purpose power amplifiers

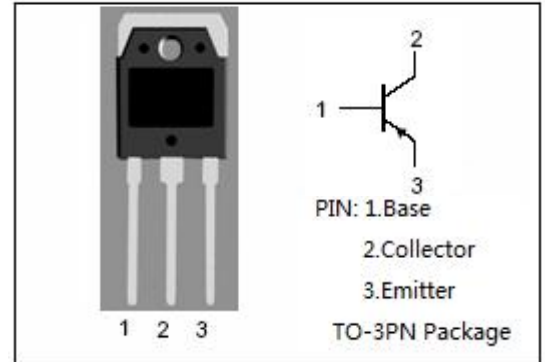

### ABSOLUTE MAXIMUM RATINGS( $T_a=25^{\circ}\text{C}$ )

SYMBOL	PARAMETER	VALUE	UNIT
$V_{CBO}$	Collector-Base Voltage	-250	V
$V_{CEO}$	Collector-Emitter Voltage	-250	V
$V_{CEX}$	Collector-Emitter Voltage $V_{EB}=5\text{V}$	-250	V
$V_{EBO}$	Emitter-Base Voltage	-5	V
$I_C$	Collector Current-Continuous	-15	A
$I_{CM}$	Collector Current-Peak	-30	A
$I_B$	Base Current-Continuous	-1.6	A
$P_T$	Total Power Dissipation @ $T_C=25^{\circ}\text{C}$	200	W
$T_J$	Junction Temperature	150	$^{\circ}\text{C}$
$T_{stg}$	Storage Temperature Range	-65~150	$^{\circ}\text{C}$

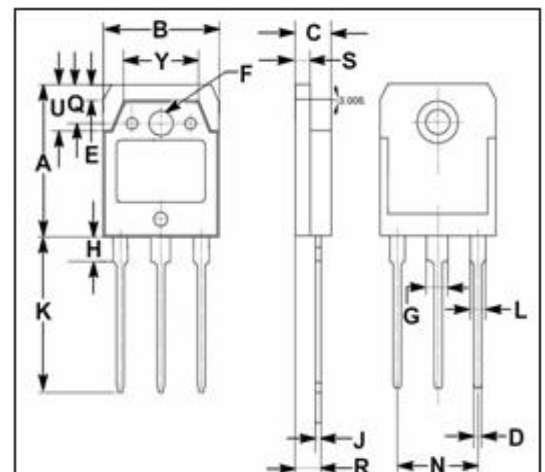

DIM	mm	
	MIN	MAX
A	19.60	20.30
B	15.50	15.70
C	4.70	4.90
D	0.90	1.10
E	1.90	2.10
F	3.40	3.60
G	2.90	3.20
H	3.20	3.40
J	0.595	0.605
K	19.80	20.70
L	1.90	2.20
N	10.89	10.91
Q	4.90	5.10
R	3.35	3.45
S	1.995	2.100
U	5.90	6.20
Y	9.90	10.10

### THERMAL CHARACTERISTICS

SYMBOL	PARAMETER	MAX	UNIT
$R_{th\ j-c}$	Thermal Resistance, Junction to Case	0.63	$^{\circ}\text{C}/\text{W}$

## SPTECH Product Specification

# SPTECH Silicon PNP Power Transistor

# NJW1302G

### ELECTRICAL CHARACTERISTICS

$T_C=25^{\circ}\text{C}$  unless otherwise specified

SYMBOL	PARAMETER	CONDITIONS	MIN	TYP.	MAX	UNIT
$V_{CE0(SUS)}$	Collector-Emitter Sustaining Voltage	$I_C=-100\text{mA}; I_B=0$	-250			V
$V_{CE(sat)}$	Collector-Emitter Saturation Voltage	$I_C=-8\text{A}; I_B=-0.8\text{A}$			-0.6	V
$V_{BE(on)}$	Base-Emitter On Voltage	$I_C=-8\text{A}; V_{CE}=-5\text{V}$			-1.5	V
$I_{CBO}$	Collector Cutoff Current	$V_{CB}=-250\text{V}$			-50	mA
$I_{CEO}$	Collector Cutoff Current	$V_{CE}=-250\text{V}$			-50	mA
$I_{EBO}$	Emitter Cutoff Current	$V_{EB}=-5\text{V}$			-5	mA
$h_{FE-1}$	DC Current Gain	$I_C=-0.1\text{A}; V_{CE}=-5\text{V}$	75		150	
$h_{FE-2}$	DC Current Gain	$I_C=-1\text{A}; V_{CE}=-5\text{V}$	75		150	
$h_{FE-3}$	DC Current Gain	$I_C=-3\text{A}; V_{CE}=-5\text{V}$	75		150	
$h_{FE-4}$	DC Current Gain	$I_C=-5\text{A}; V_{CE}=-5\text{V}$	60			
$h_{FE-5}$	DC Current Gain	$I_C=-8\text{A}; V_{CE}=-5\text{V}$	45			